

An Introduction to Design Patterns

Douglas C. Schmidt
Vanderbilt University

schmidt@dre.vanderbilt.edu

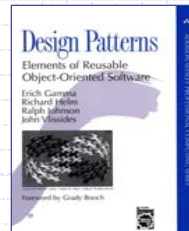

Based on material produced by John Vlissides

1

Overview

Part I: Motivation & Concept

- the issue
- what design patterns are
- what they're good for
- how we develop & categorize them

2

Overview (cont'd)

Part II: Application

- use patterns to design a document editor
- demonstrate usage & benefits

Part III: Wrap-Up

- observations, caveats, & conclusion

3

Part I: Motivation & Concept

OOD methods emphasize design notations
Fine for specification, documentation

But OOD is more than just drawing diagrams

Good OO designers rely on lots of experience
At least as important as syntax

Most powerful reuse is *design* reuse
Match problem to design experience

4

Part I: Motivation & Concept (cont'd)

Recurring Design Structures

OO systems exhibit recurring structures that promote

- abstraction
- flexibility
- modularity
- elegance

Therein lies valuable design knowledge

Problem:

capturing, communicating, & applying this knowledge

5

Part I: Motivation & Concept (cont'd)

A Design Pattern...

- abstracts a recurring design structure
- comprises class and/or object
 - dependencies
 - structures
 - interactions
 - conventions
- names & specifies the design structure explicitly
- distills design experience

6

Part I: Motivation & Concept (cont'd)

Four Basic Parts

1. Name
2. Problem
3. Solution
4. Consequences & trade-offs of application

Language- & implementation-independent

A "micro-architecture"

Adjunct to existing methodologies (RUP, Fusion, SCRUM, etc.)

7

Part I: Motivation & Concept (cont'd)

Example: OBSERVER

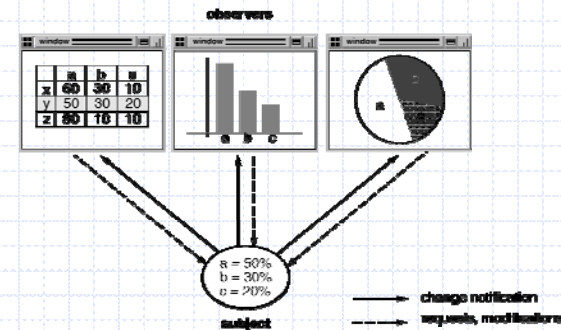

8

Part I: Motivation & Concept (cont'd)

Goals

Codify good design

- distill & generalize experience
- aid to novices & experts alike

Give design structures explicit names

- common vocabulary
- reduced complexity
- greater expressiveness

Capture & preserve design information

- articulate design decisions succinctly
- improve documentation

Facilitate restructuring/refactoring

- patterns are interrelated
- additional flexibility

9

Part I: Motivation & Concept (cont'd)

Design Space for GoF Patterns

		Purpose		
		Creational	Structural	Behavioral
Scope	Class	Factory Method	Adapter (class)	Interpreter Template Method
	Object	Abstract Factory Builder Prototype Singleton	Adapter (object) Bridge Composite Decorator Flyweight Facade Proxy	Chain of Responsibility Command Iterator Mediator Memento Observer State Strategy Visitor

Scope: domain over which a pattern applies

Purpose: reflects what a pattern does

10

Part I: Motivation & Concept (cont'd)

Design Pattern Template (1st half)

NAME scope purpose

Intent

short description of the pattern & its purpose

Also Known As

other well-known names for the pattern, if any

Motivation

motivating scenario demonstrating pattern's use

Applicability

circumstances in which pattern applies

Structure

graphical representation of the pattern using modified OMT notation

Participants

participating classes and/or objects & their responsibilities

11

Part I: Motivation & Concept (cont'd)

Design Pattern Template (2nd half)

...

Collaborations

how participants cooperate to carry out their responsibilities

Consequences

the results of application, benefits, liabilities

Implementation

pitfalls, hints, techniques, plus language-dependent issues

Sample Code

sample implementations in C++, Java, C#, Smalltalk, C, etc.

Known Uses

examples drawn from existing systems

Related Patterns

discussion of other patterns that relate to this one

12

Part I: Motivation & Concept (cont'd)
Modified UML/OMT Notation

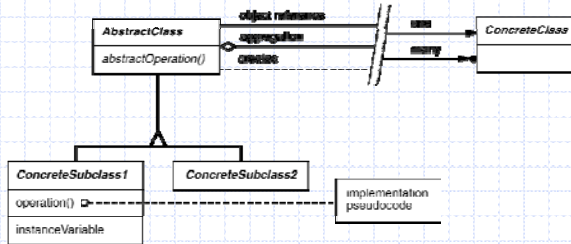

13

Motivation & Concept (cont'd)

OBSERVER object behavioral

Intent

define a one-to-many dependency between objects so that when one object changes state, all dependents are notified & updated

Applicability

- an abstraction has two aspects, one dependent on the other
- a change to one object requires changing untold others
- an object should notify unknown other objects

Structure

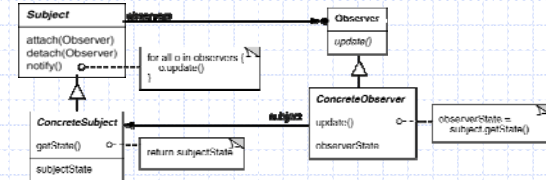

14

Motivation & Concept (cont'd)

OBSERVER (cont'd) object behavioral

Consequences

- + modularity: subject & observers may vary independently
- + extensibility: can define & add any number of observers
- + customizability: different observers offer different views of subject
- update overhead: blind to the ultimate cost

Implementation

- subject-observer mapping
- dangling references in observers.
- update protocols: the push & pull models
- registering modifications of interest explicitly

Known Uses

- Smalltalk Model-View-Controller (MVC)
- InterViews (Subjects & Views, Observer/Observable)
- Andrew (Data Objects & Views)
- Mailing lists

15

Part I: Motivation & Concept (cont'd)

Benefits of Patterns

- *Design reuse*
- Uniform design vocabulary
- Enhance understanding, restructuring, & team communication
- Basis for automation
- Transcends language-centric biases/myopia
- Abstracts away from many unimportant details

16

Part I: Motivation & Concept (cont'd)

Liabilities of Patterns

- Require significant tedious & error-prone human effort to handcraft pattern implementations *design reuse*
- Can be deceptively simple uniform design vocabulary
- Leaves some important details unresolved

17

Part II: Application: Document Editor (Lexi)

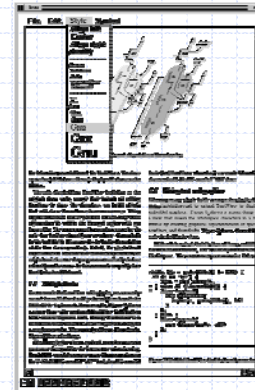

7 Design Problems

1. Document structure
2. Formatting
3. Embellishment
4. Multiple look & feels
5. Multiple window systems
6. User operations
7. Spelling checking & hyphenation

18

Document Structure

Goals:

- present document's visual aspects
- drawing, hit detection, alignment
- support physical structure (e.g., lines, columns)

Constraints/forces:

- treat text & graphics uniformly
- no distinction between one & many

19

Document Structure (cont'd)

Solution: Recursive Composition

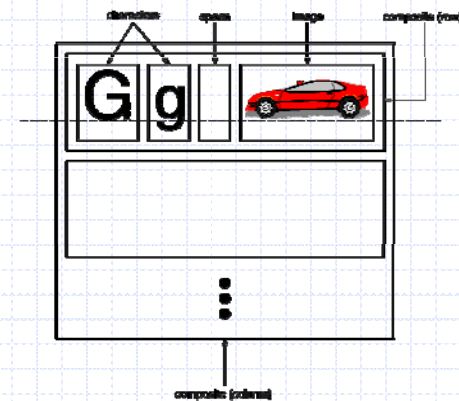

20

Document Structure (cont'd)
Object Structure

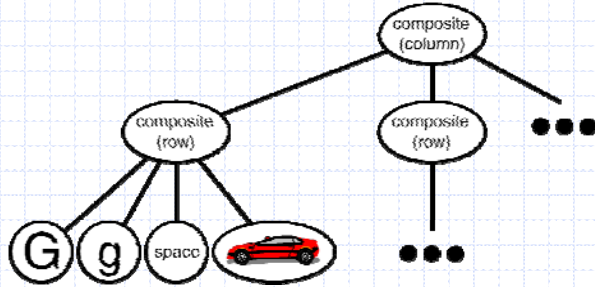

Document Structure (cont'd)
Glyph

Base class for composable graphical objects

Basic interface:

Task	Operations
appearance	<code>void draw(Window)</code>
hit detection	<code>boolean intersects(Coord, Coord)</code>
structure	<code>void insert(Glyph)</code> <code>void remove(Glyph)</code> <code>Glyph child(int)</code> <code>Glyph parent()</code>

Subclasses: Character, Image, Space, Row, Column

Document Structure (cont'd)
Glyph Hierarchy

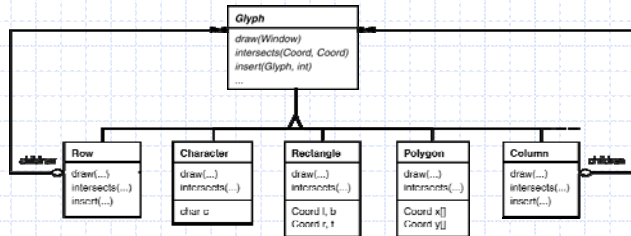

Note the inherent recursion in this hierarchy
 ♦ i.e., a Row *is* a Glyph & a Row also *has* Glyphs!

Document Structure (cont'd)

COMPOSITE object structural

Intent

treat individual objects & multiple, recursively-composed objects uniformly

Applicability

objects must be composed recursively, *and* no distinction between individual & composed elements, *and* objects in structure can be treated uniformly

Structure

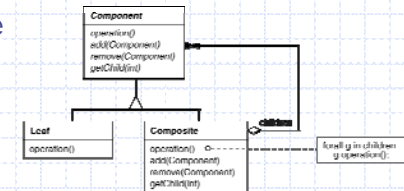

Document Structure (cont'd)

COMPOSITE (cont'd)

object structural

Consequences

- + uniformity: treat components the same regardless of complexity
- + extensibility: new Component subclasses work wherever old ones do
- overhead: might need prohibitive numbers of objects

Implementation

- do Components know their parents?
- uniform interface for both leaves & composites?
- don't allocate storage for children in Component base class
- responsibility for deleting children

Known Uses

- ET++ Vobjects
- InterViews Glyphs, Styles
- Unidraw Components, MacroCommands

25

Formatting

Goals:

- automatic linebreaking, justification

Constraints/forces:

- support multiple linebreaking algorithms
- don't tightly couple these algorithms with the document structure

26

Formatting (cont'd)

Solution: Encapsulate Linebreaking Strategy

Compositor

- base class abstracts linebreaking algorithm
- subclasses for specialized algorithms, e.g., **SimpleCompositor**, **TeXCompositor**

Composition

- composite glyph
- supplied a compositor & leaf glyphs
- creates row-column structure as directed by compositor

27

Formatting (cont'd)

New Object Structure

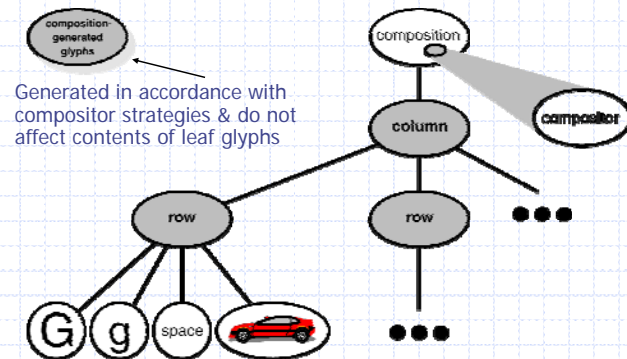

28

Formatting (cont'd)

STRATEGY

object behavioral

Intent

define a family of algorithms, encapsulate each one, & make them interchangeable to let clients & algorithms vary independently

Applicability

when an object should be configurable with one of many algorithms, *and* all algorithms can be encapsulated, *and* one interface covers all encapsulations

Structure

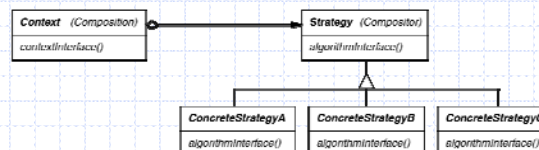

29

Formatting (cont'd)

STRATEGY (cont'd)

object behavioral

Consequences

- + greater flexibility, reuse
- + can change algorithms dynamically
- strategy creation & communication overhead
- inflexible Strategy interface
- semantic incompatibility of multiple strategies used together

Implementation

- exchanging information between a Strategy & its context
- static strategy selection via templates

Known Uses

- InterViews text formatting
- RTL register allocation & scheduling strategies
- ET++SwapsManager calculation engines

See Also

- Bridge pattern (object structural)

30

Embellishment

Goals:

- add a frame around text composition
- add scrolling capability

Constraints:

- embellishments should be reusable without subclassing, i.e., so they can be added dynamically at runtime
- should go unnoticed by clients

31

Embellishment (cont'd)

Solution: "Transparent" Enclosure

Monoglyph

- base class for glyphs having *one* child
- operations on MonoGlyph pass through to child

MonoGlyph subclasses:

- **Frame**: adds a border of specified width
- **Scroller**: scrolls/clips child, adds scrollbars

32

Embellishment (cont'd)

MonoGlyph Hierarchy

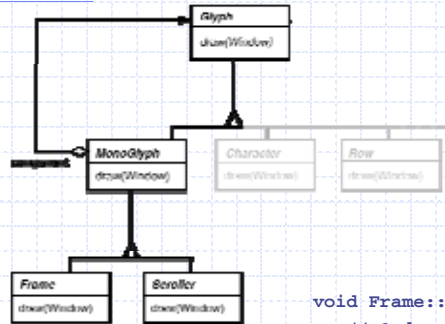

```

void Frame::draw (Window &w) {
    // Order may be important!
    MonoGlyph::draw (w);
    drawFrame (w);
}

void MonoGlyph::draw (Window &w) {
    component->draw (w);
}
    
```

33

Embellishment (cont'd)

New Object Structure

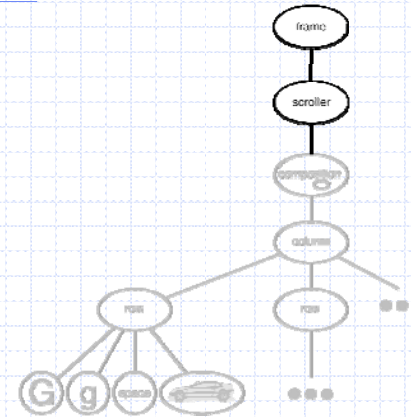

34

Embellishment (cont'd)

DECORATOR

object structural

Intent

augment objects with new responsibilities

Applicability

- when extension by subclassing is impractical
- for responsibilities that can be withdrawn

Structure

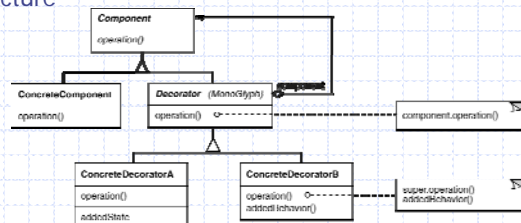

35

Embellishment (cont'd)

DECORATOR (cont'd)

object structural

Consequences

- + responsibilities can be added/removed at run-time
- + avoids subclass explosion
- + recursive nesting allows multiple responsibilities
- interface occlusion
- identity crisis
- Lots of little objects

Implementation

- interface conformance
- use a lightweight, abstract base class for Decorator
- heavyweight base classes make Strategy more attractive

Known Uses

- embellishment objects from most OO-GUI toolkits
- ParcPlace PassivityWrapper
- InterViews DebuggingGlyph

36

Multiple Look & Feels

Goals:

- support multiple look & feel standards
- generic, Motif, Swing, PM, Macintosh, Windows, ...
- extensible for future standards

Constraints:

- don't recode existing widgets or clients
- switch look & feel without recompiling

37

Multiple Look & Feels (cont'd)

Solution: Abstract Object Creation

Instead of

```
Scrollbar *sb = new MotifScrollbar();
```

USE

```
Scrollbar *sb = factory->createScrollbar();
```

where **factory** is an instance of **MotifFactory**

- BTW, this begs the question of who created the **factory**!

38

Multiple Look & Feels (cont'd)

Factory Interface

- defines "manufacturing interface"
- subclasses produce specific products
- subclass instance chosen at run-time

```
// This class is essentially a Java interface
class Factory {
public:
    Scrollbar *createScrollbar() = 0;
    Menu *createMenu() = 0;
    ...
};
```

39

Multiple Look & Feels (cont'd)

Factory Structure

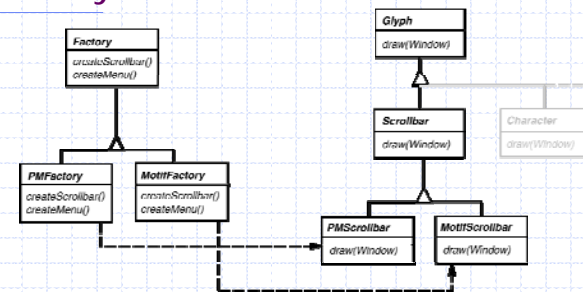

```
Scrollbar *MotifFactory::createScrollBar () {
    return new MotifScrollbar();
}
Scrollbar *PMFactory::createScrollBar () {
    return new PMScrollbar();
}
```

40

Multiple Look & Feels (cont'd)

ABSTRACT FACTORY object creational

Intent

create families of related objects without specifying class names

Applicability

when clients cannot anticipate groups of classes to instantiate

Structure

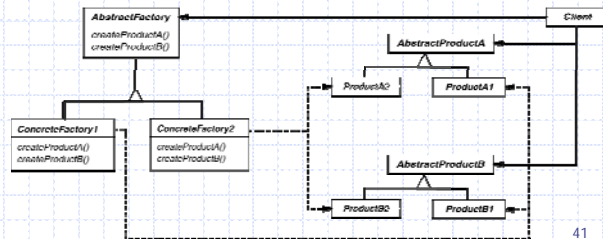

41

Multiple Look & Feels (cont'd)

ABSTRACT FACTORY (cont'd) object creational

Consequences

- + flexibility: removes type dependencies from clients
- + abstraction: hides product's composition
- hard to extend factory interface to create new products

Implementation

- parameterization as a way of controlling interface size
- configuration with Prototypes, i.e., determines who creates the factories

Known Uses

- InterViews Kits
- ET++ WindowSystem
- AWT Toolkit

42

Multiple Window Systems

Goals:

- make composition appear in a window
- support multiple window systems

Constraints:

- minimize window system dependencies in application & framework code

43

Multiple Window Systems (cont'd)

Solution: Encapsulate Implementation Dependencies

Window

- user-level window abstraction
- displays a glyph (structure)
- window system-independent
- task-related subclasses (e.g., IconWindow, PopupWindow)

44

Multiple Window Systems (cont'd)

Window Interface

```
class Window {
public:
    ...
    void iconify();           // window-management
    void raise();
    ...
    void drawLine(...);     // device-independent
    void drawText(...);     // graphics interface
    ...
};
```

45

Multiple Window Systems (cont'd)

Window uses a WindowRep

- abstract implementation interface
- encapsulates window system dependencies
- window systems-specific subclasses (e.g., XWindowRep, SunWindowRep)

An Abstract Factory can produce the right WindowRep!

46

Multiple Window Systems (cont'd)

Window/WindowRep Structure

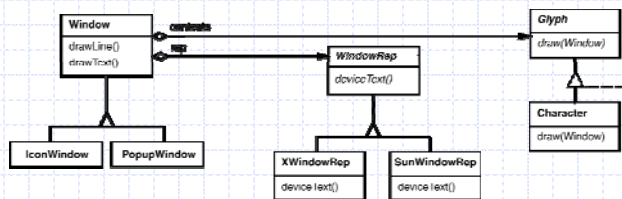

```
void Character::draw (Window &w) {
    w.drawText(...);
}
void Window::drawText (...) {
    rep->deviceText (...);
}
void XWindowRep::deviceText (...) {
    XText (...);
}
```

47

Multiple Window Systems (cont'd)

New Object Structure

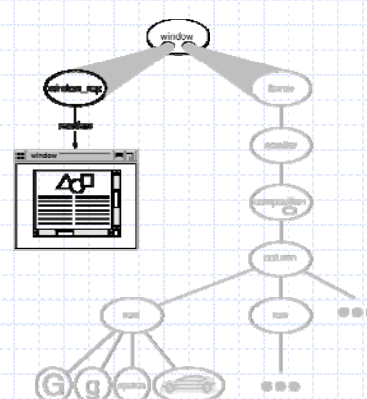

Note the decoupling between the logical structure of the contents in a window from the physical rendering of the contents in the window

48

Multiple Window Systems (cont'd)

BRIDGE

object structural

Intent

separate a (logical) abstraction interface from its (physical) implementation(s)

Applicability

- when interface & implementation should vary independently
- require a uniform interface to interchangeable class hierarchies

Structure

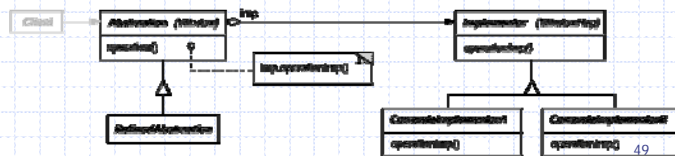

Multiple Window Systems (cont'd)

BRIDGE (cont'd)

object structural

Consequences

- + abstraction interface & implementation are independent
- + implementations can vary dynamically
- one-size-fits-all Abstraction & Implementor interfaces

Implementation

- sharing Implementors & reference counting
- creating the right implementor

Known Uses

- ET++ Window/WindowPort
- libg++ Set/{LinkedList, HashTable}
- AWT Component/ComponentPeer

50

User Operations

Goals:

- support execution of user operations
- support unlimited-level undo

Constraints:

- scattered operation implementations
- must store undo state
- not all operations are undoable

51

User Operations (cont'd)

Solution: Encapsulate Each Request

A **Command** encapsulates

- an operation (**execute()**)
- an inverse operation (**unexecute()**)
- a operation for testing reversibility (**boolean reversible()**)
- state for (un)doing the operation

Command may

- implement the operations itself, *or*
- delegate them to other object(s)

52

User Operations (cont'd)

Command Hierarchy

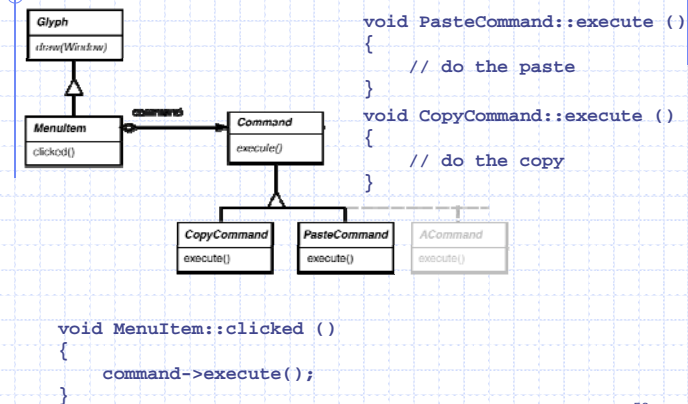

User Operations (cont'd)

List of Commands = Execution History

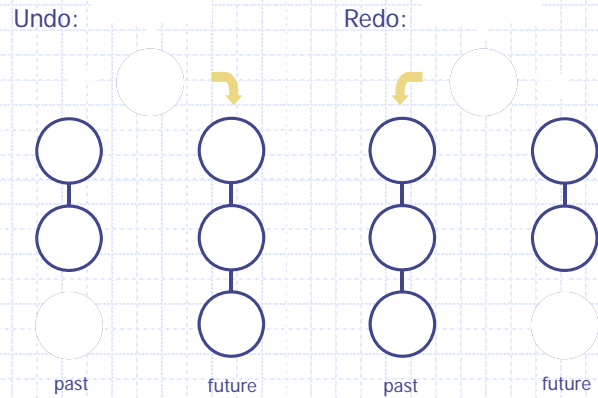

User Operations (cont'd)

COMMAND object behavioral

Intent

encapsulate the request for a service

Applicability

- to parameterize objects with an action to perform
- to specify, queue, & execute requests at different times
- for multilevel undo/redo

Structure

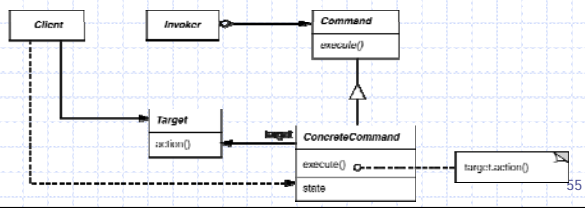

User Operations (cont'd)

COMMAND (cont'd) object behavioral

Consequences

- + abstracts executor of a service
- + supports arbitrary-level undo-redo
- + composition yields macro-commands
- might result in lots of trivial command subclasses

Implementation

- copying a command before putting it on a history list
- handling hysteresis
- supporting transactions

Known Uses

- InterViews Actions
- MacApp, Unidraw Commands
- JDK's UndoableEdit, AccessibleAction

Spelling Checking & Hyphenation

Goals:

- analyze text for spelling errors
- introduce potential hyphenation sites

Constraints:

- support multiple algorithms
- don't tightly couple algorithms with document structure

57

Spelling Checking & Hyphenation (cont'd)

Solution: Encapsulate Traversal

Iterator

- encapsulates a traversal algorithm without exposing representation details to callers
- uses Glyph's child enumeration operation
- This is an example of a "preorder iterator"

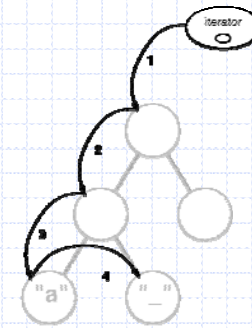

58

Spelling Checking & Hyphenation (cont'd)

ITERATOR object behavioral

Intent

access elements of a container without exposing its representation

Applicability

- require multiple traversal algorithms over a container
- require a uniform traversal interface over different containers
- when container classes & traversal algorithm must vary independently

Structure

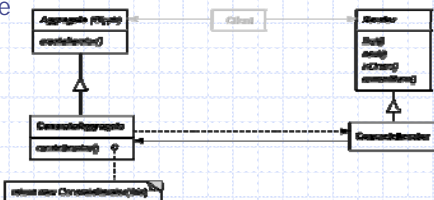

59

Spelling Checking & Hyphenation (cont'd)

ITERATOR (cont'd) object behavioral

Iterators are used heavily in the C++ Standard Template Library (STL)

```
int main (int argc, char *argv[]) {
    vector<string> args;

    for (int i = 0; i < argc; i++)
        args.push_back (string (argv[i]));

    for (vector<string>::iterator i (args.begin ());
         i != args.end ();
         i++)
        cout << *i;

    cout << endl;
    return 0;
}
```

The same iterator pattern can be applied to any STL container!

60

Spelling Checking & Hyphenation (cont'd)

ITERATOR (cont'd) object behavioral

Consequences

- + flexibility: aggregate & traversal are independent
- + multiple iterators & multiple traversal algorithms
- additional communication overhead between iterator & aggregate

Implementation

- internal versus external iterators
- violating the object structure's encapsulation
- robust iterators

Known Uses

- C++ STL iterators
- JDK Enumeration, Iterator
- Unidraw Iterator

61

Spelling Checking & Hyphenation (cont'd)

Visitor

- defines action(s) at each step of traversal
- avoids wiring action(s) into Glyphs
- iterator calls glyph's `accept(Visitor)` at each node
- `accept()` calls back on visitor (a form of "static polymorphism" based on method overloading by type)

```
void Character::accept (Visitor &v) { v.visit (*this); }

class Visitor {
public:
    virtual void visit (Character &);
    virtual void visit (Rectangle &);
    virtual void visit (Row &);
    // etc. for all relevant Glyph subclasses
};
```

62

Spelling Checking & Hyphenation (cont'd)

SpellingCheckerVisitor

- gets character code from each character glyph
Can define `getCharCode()` operation just on `Character()` class
- checks words accumulated from character glyphs
- combine with **PreorderIterator**

```
class SpellCheckerVisitor : public Visitor {
public:
    void visit (Character &);
    void visit (Rectangle &);
    void visit (Row &);
    // etc. for all relevant Glyph subclasses
};
```

63

Spelling Checking & Hyphenation (cont'd)

Accumulating Words

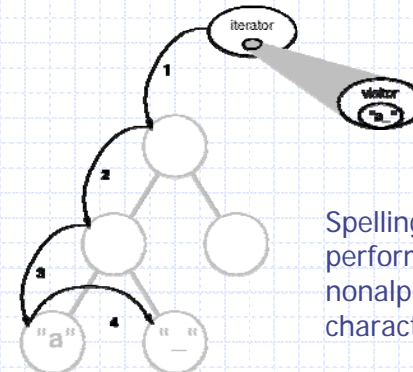

Spelling check performed when a nonalphabetic character it reached

64

Spelling Checking & Hyphenation (cont'd)

Interaction Diagram

- The iterator controls the order in which accept() is called on each glyph in the composition
- accept() then "visits" the glyph to perform the desired action
- The Visitor can be subclassed to implement various desired actions

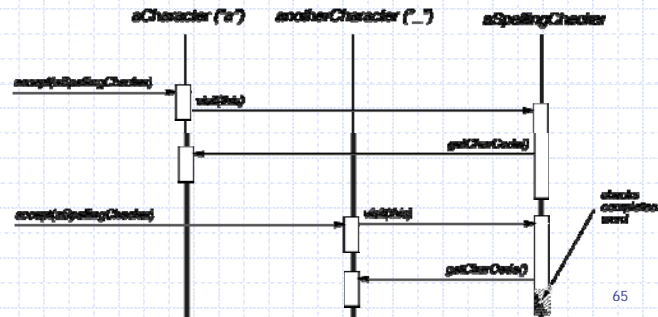

65

Spelling Checking & Hyphenation (cont'd)

HyphenationVisitor

- gets character code from each character glyph
- examines words accumulated from character glyphs
- at potential hyphenation point, inserts a...

```

class HyphenationVisitor : public Visitor {
public:
    void visit (Character &);
    void visit (Rectangle &);
    void visit (Row &);
    // etc. for all relevant Glyph subclasses
};
    
```

66

Spelling Checking & Hyphenation (cont'd)

Discretionary Glyph

- looks like a hyphen when at end of a line
- has no appearance otherwise
- Compositor considers its presence when determining linebreaks



aluminum alloy

or

aluminum al-
loy

67

Spelling Checking & Hyphenation (cont'd)

VISITOR object behavioral

Intent

centralize operations on an object structure so that they can vary independently but still behave polymorphically

Applicability

- when classes define many unrelated operations
- class relationships of objects in the structure rarely change, but the operations on them change often
- algorithms keep state that's updated during traversal

Structure

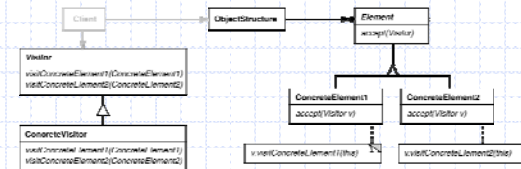

68

Spelling Checking & Hyphenation (cont'd)

VISITOR (cont'd) object behavioral

Consequences

- + flexibility: visitor & object structure are independent
- + localized functionality
- circular dependency between Visitor & Element interfaces
- Visitor brittle to new ConcreteElement classes

Implementation

- double dispatch
- general interface to elements of object structure

Known Uses

- ProgramNodeEnumerator in Smalltalk-80 compiler
- IRIS Inventor scene rendering
- TAO IDL compiler to handle different backends

69

Part III: Wrap-Up

Observations

Patterns are applicable in all stages of the OO lifecycle

- design & reviews
- realization & documentation
- reuse & refactoring

Patterns permit design at a more abstract level

- treat many class/object interactions as a unit
- often beneficial *after* initial design
- targets for class refactorings

Variation-oriented design

- consider what design aspects are variable
- identify applicable pattern(s)
- vary patterns to evaluate tradeoffs
- repeat

70

Part III: Wrap-Up (cont'd)

But...

Don't apply them blindly

Added indirection can yield increased complexity, cost

Resist branding everything a pattern

Articulate specific benefits

Demonstrate wide applicability

Find at least *three* existing examples from code other than your own!

Pattern design even harder than OO design!

71

Part III: Wrap-Up (cont'd)

Concluding Remarks

- *design* reuse
- uniform design vocabulary
- understanding, restructuring, & team communication
- provides the basis for automation
- a "new" way to think about design

72

Pattern References

Books

The Timeless Way of Building, Alexander, ISBN 0-19-502402-8
A Pattern Language, Alexander, 0-19-501-919-9
Design Patterns, Gamma, et al., 0-201-63361-2
CD version 0-201-63498-8
Pattern-Oriented Software Architecture, Buschmann, et al.,
0-471-95869-7
Pattern-Oriented Software Architecture, Vol. 2, Schmidt, et
al.,
0-471-60695-2
Pattern-Oriented Software Architecture, Vol. 3, Jain & Kircher,
et al.,
0-470-84525-2
Analysis Patterns, Fowler; 0-201-89542-0

73

Pattern References (cont'd)

More Books

Concurrent Programming in Java, 2nd ed., Lea, 0-201-31009-0
Pattern Languages of Program Design
Vol. 1, Coplien, et al., eds., ISBN 0-201-60734-4
Vol. 2, Vlissides, et al., eds., 0-201-89527-7
Vol. 3, Martin, et al., eds., 0-201-31011-2
Vol. 4, Harrison, et al., eds., 0-201-43304-4
AntiPatterns, Brown, et al., 0-471-19713-0
Applying UML & Patterns, 2nd ed., Larman, 0-13-092569-1
Pattern Hatching, Vlissides, 0-201-43293-5
The Pattern Almanac 2000, Rising, 0-201-61567-3

74

Pattern References (cont'd)

Even More Books

Small Memory Software, Noble & Weir, 0-201-59607-5
Microsoft Visual Basic Design Patterns, Stamatakis, 1-572-31957-7
Smalltalk Best Practice Patterns, Beck; 0-13-476904-X
The Design Patterns Smalltalk Companion, Alpert, et al.,
0-201-18462-1
Modern C++ Design, Alexandrescu, ISBN 0-201-70431-5
Building Parsers with Java, Metsker, 0-201-71962-2

75

Pattern References (cont'd)

New Books

Core J2EE Patterns, Alur, et al., 0-130-64884-1
Design Patterns Explained, Shalloway & Trott, 0-201-71594-5
The Joy of Patterns, Goldfedder, 0-201-65759-7
The Manager Pool, Olson & Stimmel, 0-201-72583-5

76

Pattern References (cont'd)

Early Papers

- "Object-Oriented Patterns," P. Coad; Comm. of the ACM, 9/92
- "Documenting Frameworks using Patterns," R. Johnson; OOPSLA '92
- "Design Patterns: Abstraction & Reuse of Object-Oriented Design," Gamma, Helm, Johnson, Vlissides, ECOOP '93

Articles

- Java Report, Java Pro, JOOP, Dr. Dobb's Journal, Java Developers Journal, C++ Report

77

Pattern-Oriented Conferences

PLoP 2006: Pattern Languages of Programs
October 2006, Collocated with OOPSLA

EuroPLoP 2006, July 2006, Kloster Irsee,
Germany

...

See hillside.net/conferencesnavigation.htm for up-to-the-minute info.

78

Mailing Lists

- patterns@cs.uiuc.edu:** present & refine patterns
- patterns-discussion@cs.uiuc.edu:** general discussion
- gang-of-4-patterns@cs.uiuc.edu:** discussion on *Design Patterns*
- siemens-patterns@cs.uiuc.edu:** discussion on *Pattern-Oriented Software Architecture*
- ui-patterns@cs.uiuc.edu:** discussion on user interface patterns
- business-patterns@cs.uiuc.edu:** discussion on patterns for business processes
- ipc-patterns@cs.uiuc.edu:** discussion on patterns for distributed systems

See <http://hillside.net/patterns/mailling.htm> for an up-to-date list.

79