

Reconfigurable Benches from Twist-Hinged Dissections of Polygonal Rings and Anti-Rings*

Greg N. Frederickson

Department of Computer Science
Purdue University, West Lafayette, Indiana 47907
gnf@cs.purdue.edu

Abstract

A geometric dissection is a cutting of a geometric figure into pieces that we can rearrange to form another figure. Twist-hinged dissections have the amazing property that all pieces are connected by special hinges that allow the one figure to be converted to the other by means of twists. This paper explores such dissections for ringlike figures based on regular polygons. The twist-hinged dissections of these figures can be adapted to create reconfigurable benches that ring a pillar or tree, exhibiting remarkable symmetry and making singular design statements.

1 Introduction

A geometric dissection is a cutting of a geometric figure into pieces that we can rearrange to form another figure [13, 21]. Such visual demonstrations of the equivalence of area span from the geometric explorations of the ancient Greeks [2, 7] to the flowering of Arabic-Islamic mathematics [1, 4, 25, 27] to the emergence of mathematical puzzle columns in newspapers and magazines [8, 9, 22, 23] to the appearance of articles on the world-wide web [28]. During the last century, the emphasis has generally been on minimizing the number of pieces for any given dissection. This emphasis on efficiency and elegance

*This is an expanded version of the paper that appeared in [18].

has catalyzed some remarkably beautiful dissections that serve as attractive ambassadors for the field of mathematics [3].

As dissection methods have become more sophisticated, attention has also focused on special properties. Most notable is the property that all pieces of a dissection be connected by hinges, so that when the pieces are swung one way on the hinges, they form one figure, and when swung the other way on the hinges, they form the other figure. A hundred years ago, Henry Dudeney demonstrated such a hinged dissection of an equilateral triangle to a square [10]. Since then, enough hinged dissections have been identified to fill a whole book on the subject [16]. The power of hinged dissections can be mesmerizing, as indicated by designers' projects to adapt the triangle-to-square dissection to art objects such as a hinged set of tables [5, 12].

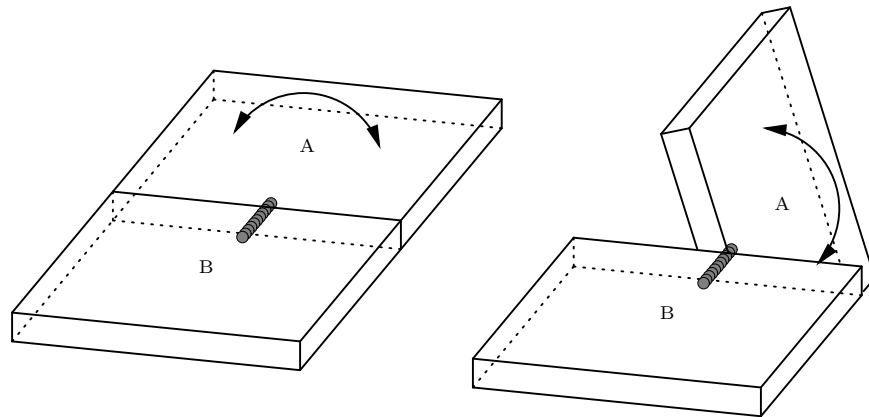

Figure 1: A twist hinge for pieces A and B

Other types of hinges have also drawn attention. A *twist hinge* has a point of rotation on the interior of the line segment along which two pieces touch edge-to-edge. It allows one piece to be flipped over relative to the other, using 180° rotation through the third dimension. Pieces A and B (with exaggerated thickness) are twist-hinged together in Figure 1.

The twist-hinged dissection of an ellipse to a heart (Figure 2) is a direct application. We mark any piece that is turned over an odd number of times with an “*” on one side and a “✱” on the other. A few isolated dissections [11, 24, 26] were the only examples of twist-hinged dissections prior to a more concerted search for them [14, 15, 16, 17, 19].

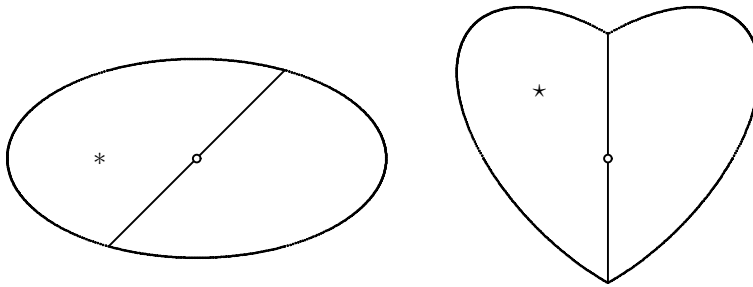

Figure 2: Twist-hinged dissection of an ellipse to a heart

In this article we shall explore twist-hinged dissections of ringlike figures that are based on regular polygons. A *regular polygon* is a polygon in which all edges have the same length and all angles have the same measure. We represent a p -sided regular polygon of side length x with the notation $x\text{-}\{p\}$. A *polygonal ring* is a regular polygon with a similar, but smaller, regular polygon cut out of it, such that the polygons share the same center and each vertex of the smaller polygon is on a line segment from a vertex of the larger polygon to its center. We represent a polygonal ring based on regular polygon $\{p\}$ of outer side length X and inner side length x with the notation $(X, x)\text{-}\{p\}$ -ring. A *polygonal anti-ring* is the same as a polygonal ring, except that each vertex of the smaller polygon is on the line segment from the midpoint of a side of the large polygon to its center. (The distinction between a polygonal ring and a polygonal anti-ring draws inspiration from the distinction between a prism and an antiprism, the latter being prism-like objects identified by Johannes Kepler [20].) In Figure 3 we see as examples both a pentagonal ring and a pentagonal anti-ring.

At first glance, one might wonder what possible application to art and design one could find for polygonal rings. Yet designers of outdoor furniture have long produced benches that ring a tree trunk or lamp post. Typically, the benches employ either a wrought-iron framework or a lattice-like construction of wood cross-braces. We show how to design, at least implicitly, such benches so that they can be reconfigured as the tree trunk expands, or alternative seating is desired! These designs are so symmetrical and appealing in their use of twisting motion that they could well be show-stoppers at any garden party.

We should note two considerations about using the twist-hinged dissections as the basis for ring benches. First, we assume that the ring benches have no backs, since it would be tricky twisting them out of the way in the alternative configuration. Second, it seems to be easy to accommodate the bench's legs. Just place them at the corners of those pieces not marked by asterisks or stars, whenever that corner is a vertex in both resulting figures. Note that a polygonal ring has vertices along the inner polygon as well as the outer polygon.

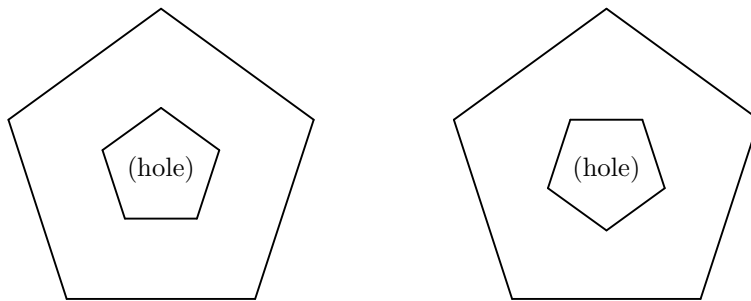

Figure 3: Pentagonal ring and pentagonal anti-ring

2 New family of twist-hinged dissections

In [6], Jean Bauer presented a number of new relationships among polygons. An especially nice one relates the polygons $\{p\}$ and $\{2p\}$ for every value of $p > 3$: When p is an even number, there is a dissection of a $(2 \cos(\pi/p))$ - $\{2p\}$, which is a $\{2p\}$ of sidelength $(2 \cos(\pi/p))$, to two $(1 + 2 \cos(\pi/p), 1)$ - $\{p\}$ -rings, which are p -sided rings whose outer side is of length $1 + 2 \cos(\pi/p)$ and whose inner side is of length 1. When p is odd, there is a dissection of a $(2 \cos(\pi/p))$ - $\{2p\}$ to two $(1 + 2 \cos(\pi/p), 1)$ - $\{p\}$ -anti-rings.

This is illustrated in Figure 4 for the case of $p = 5$, and derives for general p from the following. As is well-known, we can arrange $2p$ rhombuses with small angle $180^\circ/p$ around a central point, then $2p$ rhombuses with small angle $2 * 180^\circ/p$ around them, and so on, for a total of $p - 3$ sets of $2p$ rhombuses. Finally, we arrange around the outermost level $2p$ isosceles triangles whose equal angles are $180^\circ/p$. We thus get a regular $2p$ -sided polygon. Bauer's observation was that we could take exactly half of the constituent rhombuses and isosceles triangles and build outwards from a regular p -sided polygon, obtaining a larger regular p -sided polygon. Of course, we can take the other half of the constituent rhombuses and isosceles triangles and get a second, identical regular p -sided polygon. Removing the two small central regular polygons leaves two polygonal rings if p is even, and two polygonal anti-rings if p is odd.

It is not difficult to see how to glue the rhombuses and isosceles triangles together to get a lovely $2p$ -piece dissection for this relationship. There is a corresponding $(4p - 2)$ -piece twist-hinged dissection. Figure 5 illustrates it for the case of $p = 5$. The decagon separates along the polygonal path that touches no triangles, and each half twists into a pentagonal anti-ring. The dissections for other values of p are analogous.

An example when p is even is illustrated in Figure 6, which shows the dissection for the case of $p = 6$. The dodecagon separates and twists into

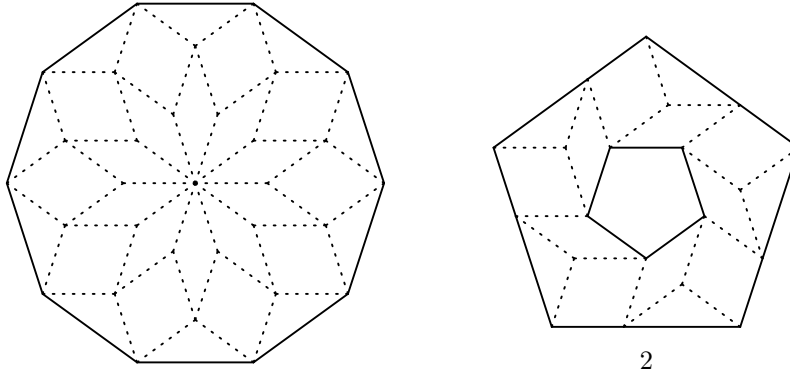

Figure 4: Rhombic structure for Bauer's relationship when $p = 5$

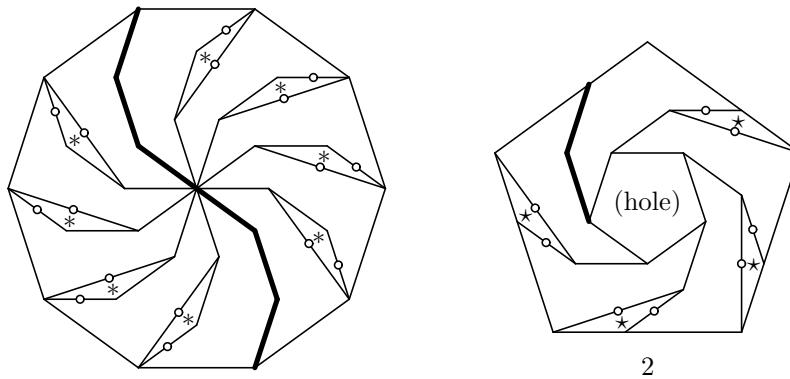

Figure 5: Twist-hinged dissection of decagon to two pentagonal anti-rings

two hexagonal rings.

3 An even larger new family

If we abandon our interest in anti-rings and focus on rings, there is an even more wonderful family of twist-hinged dissections. The first example, in Figure 7, is a twist-hinged dissection of a $(1 + \phi, 1)$ -decagonal ring to two $(2 + \phi)$ -pentagons. (Recall that ϕ is the golden ratio, which is approximately 1.618). The second example, in Figure 8, is a twist-hinged dissection of a

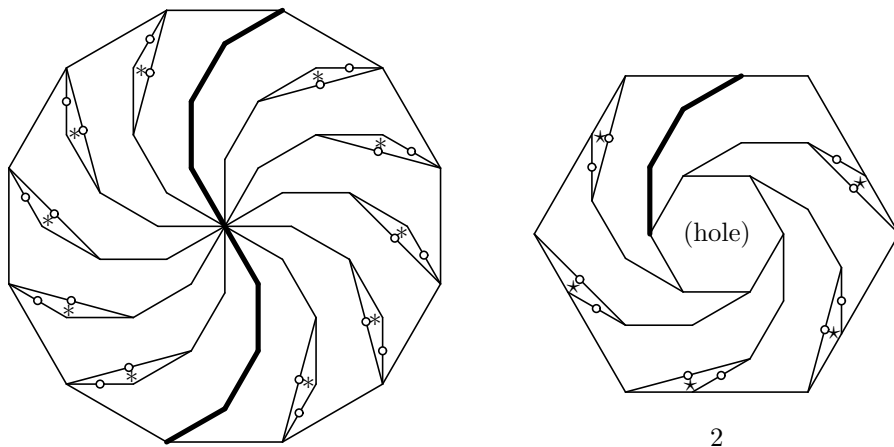

Figure 6: Twist-hinged dissection of dodecagon to two hexagonal rings

$(\sqrt{3}, 1)$ -dodecagonal ring to three $(1+\sqrt{3})$ -squares.

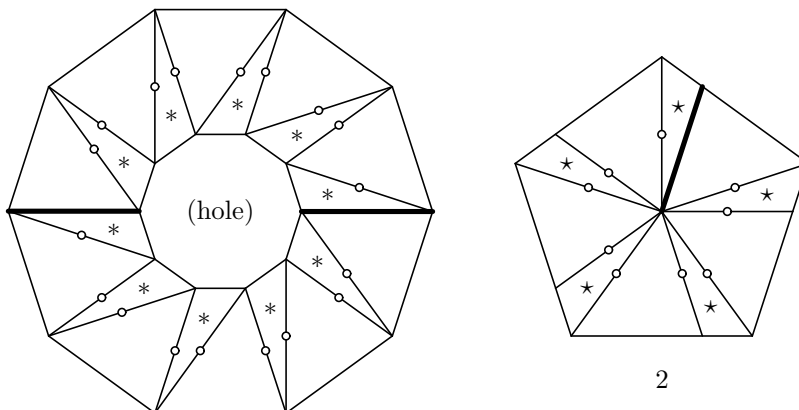

Figure 7: Twist-hinged dissection of a decagonal ring to two pentagons

We can also dissect multiple rings to many other rings. The example in Figure 9 is a twist-hinged dissection of two dodecagonal rings to three octagonal rings. The ratio of the inner side length of the dodecagonal ring to the inner side length of the octagonal ring can vary over a wide range, and the outer side lengths of the polygonal rings depend on these values. In

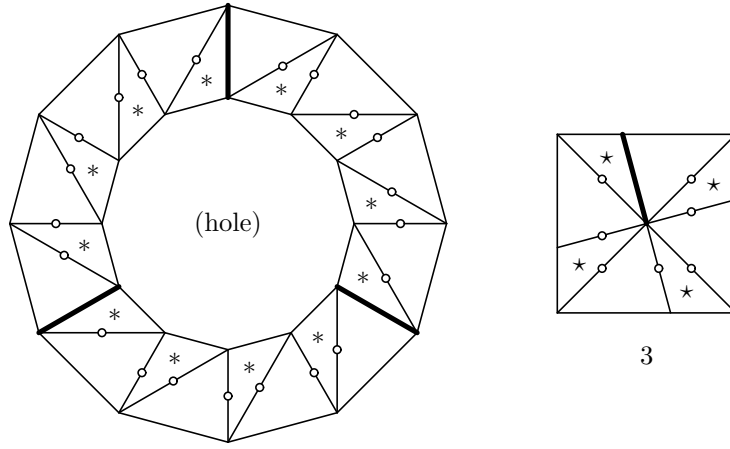

Figure 8: Twist-hinged dissection of a dodecagonal ring to three squares

Figure 9, we choose a ratio of 4 : 3 for the ratio of the inner side length of the dodecagonal ring to the inner side length of the octagonal ring.

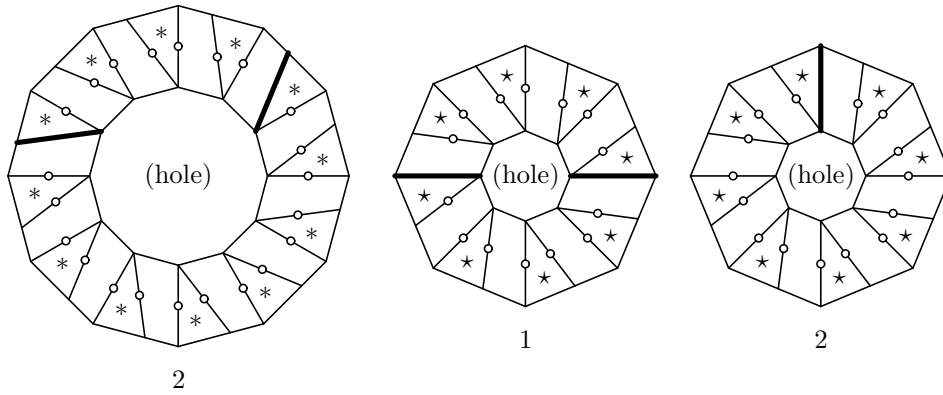

Figure 9: Twist-hinged two dodecagonal rings to three octagonal rings

To create such a dissection, we first choose the number of sides in each of the two different polygonal rings: choose p and q to be natural numbers with $p > q$. We next determine the multiplicity of each type of polygonal ring. Let $g = \gcd(p, q)$, the greatest common divisor of p and q . There will

be q/g $\{p\}$ -rings and p/g $\{q\}$ -rings. Next we choose the lengths of the inner sides of the polygonal rings: x will be the inner side length of the $\{p\}$ -rings, and y will be the inner side length of the $\{q\}$ -rings, with $x > y \geq 0$.

Let $h = (x-y)/(\tan(\pi/q) - \tan(\pi/p))$. Let $z = (x-y) + 2h \tan(\pi/p)$. We can determine the outer side lengths of the polygonal rings: $X = y + z$ will be the outer side length of the $\{p\}$ -rings and $Y = x + z$ will be the outer side length of the $\{q\}$ -rings. We cut the pieces in a way consistent with what we do in Figure 9, and then hinge in a greedy fashion: Starting with the first $\{p\}$ -ring and the first $\{q\}$ -ring, hinge as many pieces as possible from what remains of the current $\{q\}$ -ring to fill up as completely as possible what remains of the current $\{p\}$ -ring. The number of twist-hinged assemblages will be one less than the total number of polygonal rings of both types.

In Figure 9, $p = 12$ and $q = 8$, and $g = \gcd(12, 8) = 4$. Thus there are $8/4 = 2$ dodecagonal rings and $12/4 = 3$ octagonal rings. Once we choose x and y , we can compute values h, z, X , and Y . There will be 4 twist-hinged assemblages: 2 from one octagonal ring, and one each from the other two octagonal rings.

When $y = 0$, the corresponding polygonal rings become simple polygons. This is the case for either of the first two examples. For the second example, of dodecagonal rings and squares, $\tan(\pi/4) = 1$ and $\tan(\pi/12) = 2 - \sqrt{3}$. When $x = 1$, $X = \sqrt{3}$ and $Y = 1 + \sqrt{3}$.

Something may seem wrong if you compare either Figure 7 or Figure 8 with Figure 9: The pieces that are not turned over in the former figures do not share sides with the inner boundary of the rings, whereas those pieces that are not turned over in the latter figure do share sides with the inner boundary of the rings. The reason is that in the latter figure, I switched which pieces get turned over, so as to not turn over the pieces of larger area. This choice makes sense if you actually wish to build ring benches!

4 An Expansion of the Second Family

There is another way to view the dissections of the previous section, which leads to a considerable expansion of the family. We note that the width of the ring, i.e., the distance from the outside to the inside, does not change. We could derive the cuts of the dissection in the following manner: Cut a $\{p\}$ -ring up into p isosceles trapezoids, which we then connect with twist-hinges, so that we can twist from the ring to a parallelogram, as in Figure 10.

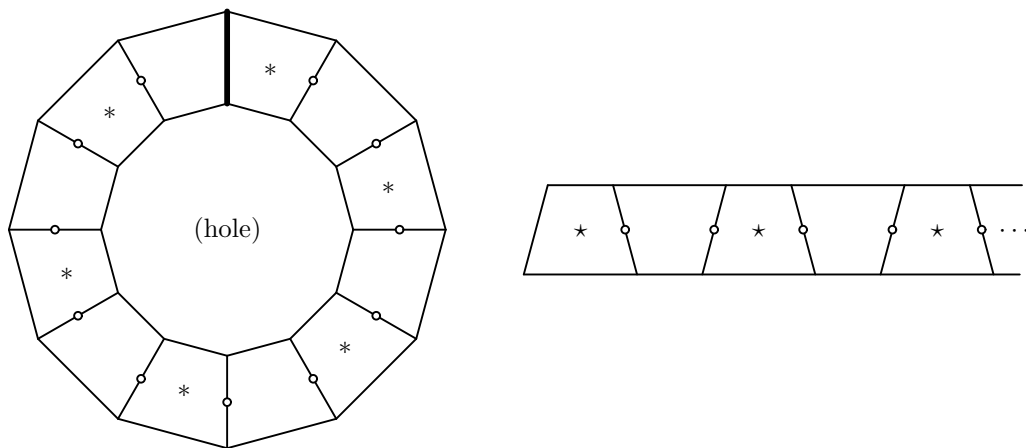

Figure 10: Twist-hinging a ring to a parallelogram or a trapezoid

Suppose that we wish to dissect the $\{p\}$ -ring into a $\{q\}$ -ring, where $q > 2$ divides evenly into p and the width of the ring is the same. Then cut up the $\{q\}$ -ring into q isosceles trapezoids, so that we will get different parallelogram but of the same length and the same height. Overlaying the two parallelograms then gives a combined set of cuts. For example, we take the dodecagonal ring from Figure 10 and dissect it into a square ring. This gives us the 16-piece twist-hinged dissection in Figure 11.

We can extend this trapezoid method in a different direction by dissecting each trapezoid into a different trapezoid. We can then dissect a $\{p\}$ -ring into a $\{q\}$ -ring and an $\{r\}$ -ring of appropriate dimensions. An example is

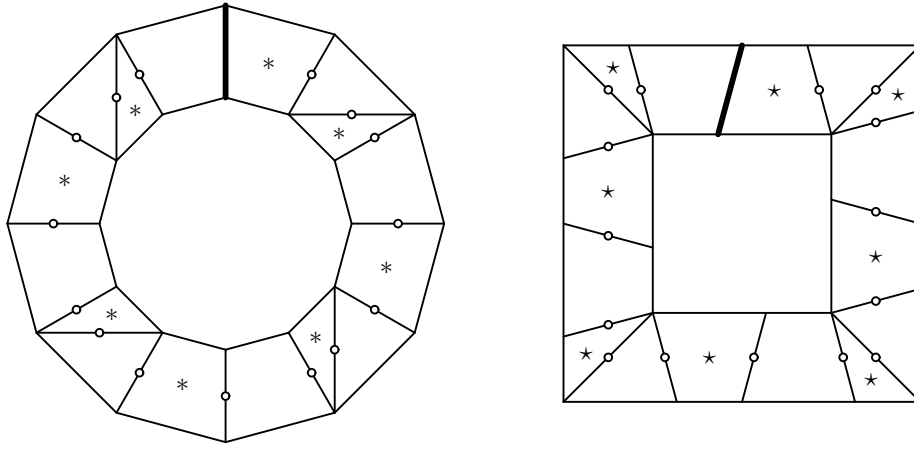

Figure 11: Twist-hinged dodecagonal ring to a “square ring”

shown in Figure 12, where $p = 12$, $q = 5$, and $r = 7$. Clearly, this approach extends to a set R of rings into a set R' of rings, where the total number of sides in the rings of R equals the total number of sides in the rings of R' .

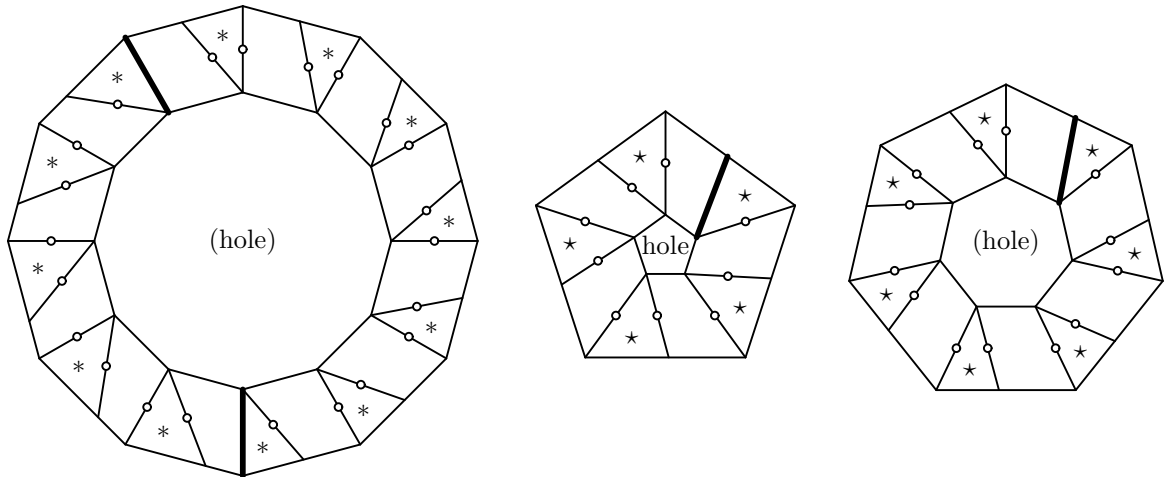

Figure 12: Twist-hinged dodecagonal ring to pentagonal and heptagonal rings

In all of this, we might ask what has happened to the possibility of

dissecting anti-rings. There is a simple trick that allows us to convert a $\{p\}$ -ring to a $\{p\}$ -anti-ring, and the other way around: Just cut p additional pieces by cutting a $\{2p\}$, half of whose vertices coincide with the p vertices of the hole. This technique is illustrated for $p = 5$ in Figure 13. It can be applied to the dissections in Figures 5, 6, 7, 8, 9, 12.

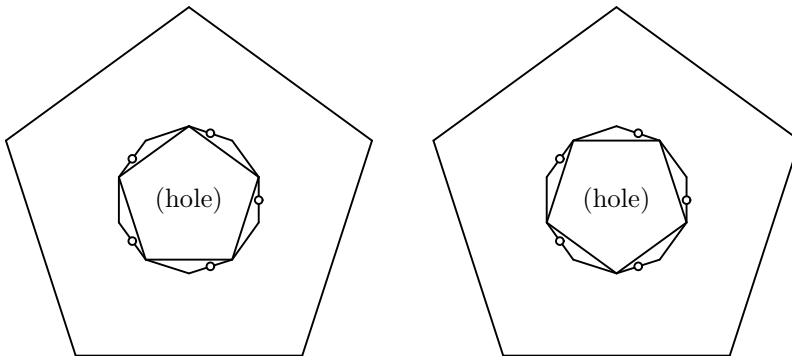

Figure 13: Twist-hinged pentagonal ring and pentagonal anti-ring

5 A Third Family of Twist-hinged Dissections

Our final family of dissections is of a $\{2p\}$ -ring to a $\{p\}$ -ring, but where the widths of the rings are not the same. Each dissection is based on a $(2p + 1)$ -piece twist-hinged dissection of a $\{2p\}$ to a $\{p\}$ from [16]. An example of such a dissection is the dissection of a regular octagon to a square in Figure 14.

We see a derivation of the dissection of Figure 14 in Figure 15. The square (in thick dashes) and the regular octagon (in solid line segments) are overlaid so that their centers coincide, and each side of the square intersects a side of the octagon at its midpoint. (Black dots indicate the midpoints.) Additional line segments (in thin dashes) identify cuts in either the square or the octagon.

To dissect a $\{2p\}$ -ring to a $\{p\}$ -ring, we will use a similar technique to “dissect” the hole. Figure 16 illustrates the derivation of the technique,

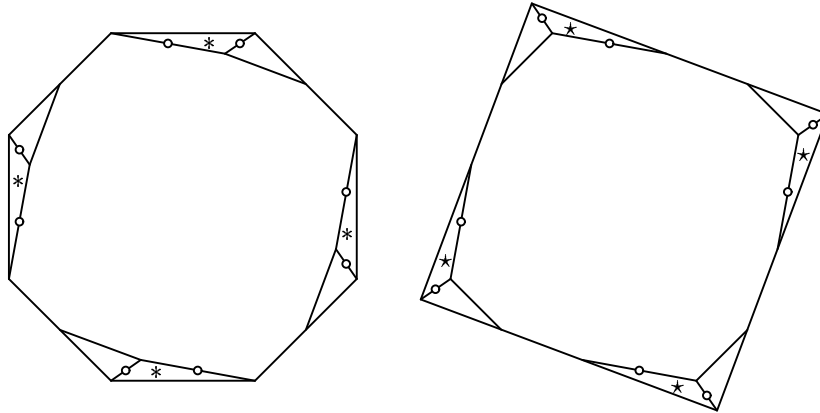

Figure 14: Twist-hinged octagon to a square

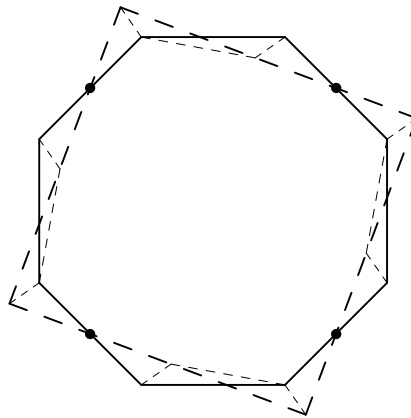

Figure 15: Derivation of twist-hinged octagon to a square

where all cuts are outside of the octagonal or square holes, whose centers coincide. We thus get the “hole dissection” in Figure 17. The hole technique creates $2p$ additional pieces.

Figure 18 displays the final 17-piece dissection of the octagonal ring to the square ring. The corresponding dissection for a $\{2p\}$ -ring to a $\{p\}$ -ring will have $4p + 1$ pieces.

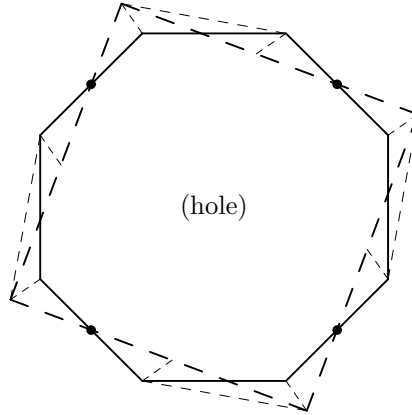

Figure 16: Derivation of twist-hinged octagonal hole to a square hole

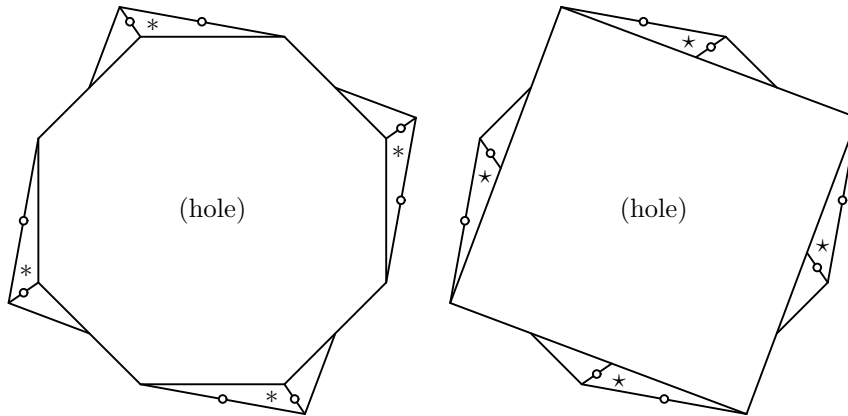

Figure 17: Twist-hinged octagonal hole to a square hole

6 Conclusion

We have described three different families of twist-hinged dissections upon which to base the design of ring benches. From a practical point of view, the second family is probably preferable, for two reasons. First, the pieces in the second family are all convex, and there are fewer sharp angles, which means that the benches should be easier to construct. Second, the pieces

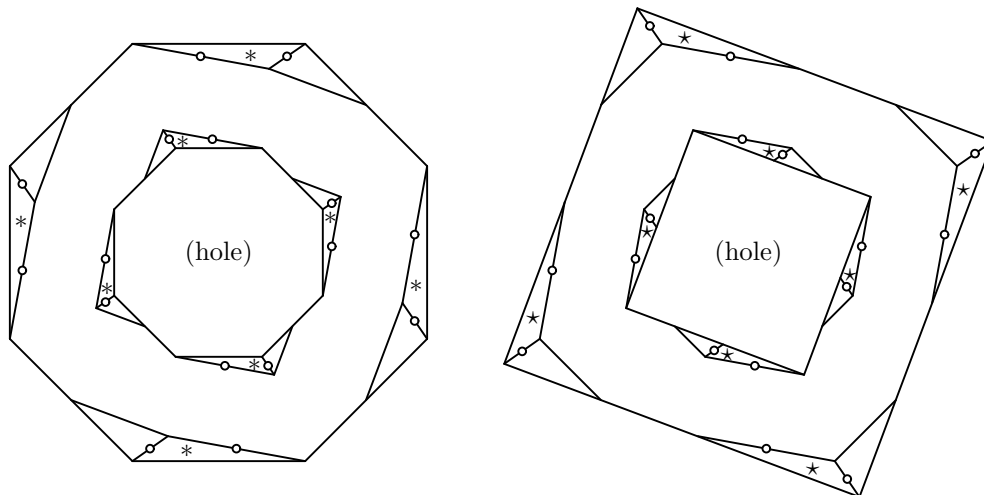

Figure 18: Twist-hinged octagonal ring to a square ring

are generally more compact in the second family, and the hinges are thus not so far from the extremities of the pieces. Then the pieces should connect together with less torque on the individual hinges. Third, all pieces are of a reasonable size and there is no question how to encircle a lamppost or a tree, as would be the case with the third family.

For each of the dissections described, it is instructive for the reader to think through the sequence of twists that take the polygonal ring or rings to their alternative figure or figures. Not just any sequence will work, because it is possible to have one piece collide with another if the wrong sequence is chosen. Figure 19 shows five snapshots in a sequence that converts the decagonal ring to two pentagons, as in Figure 7. At the top, we slide the two assemblages apart. We then work simultaneously on each end of the two assemblages, showing the last four pairs of twists on each assemblage. We identify the twist hinges that take part in each of those twists.

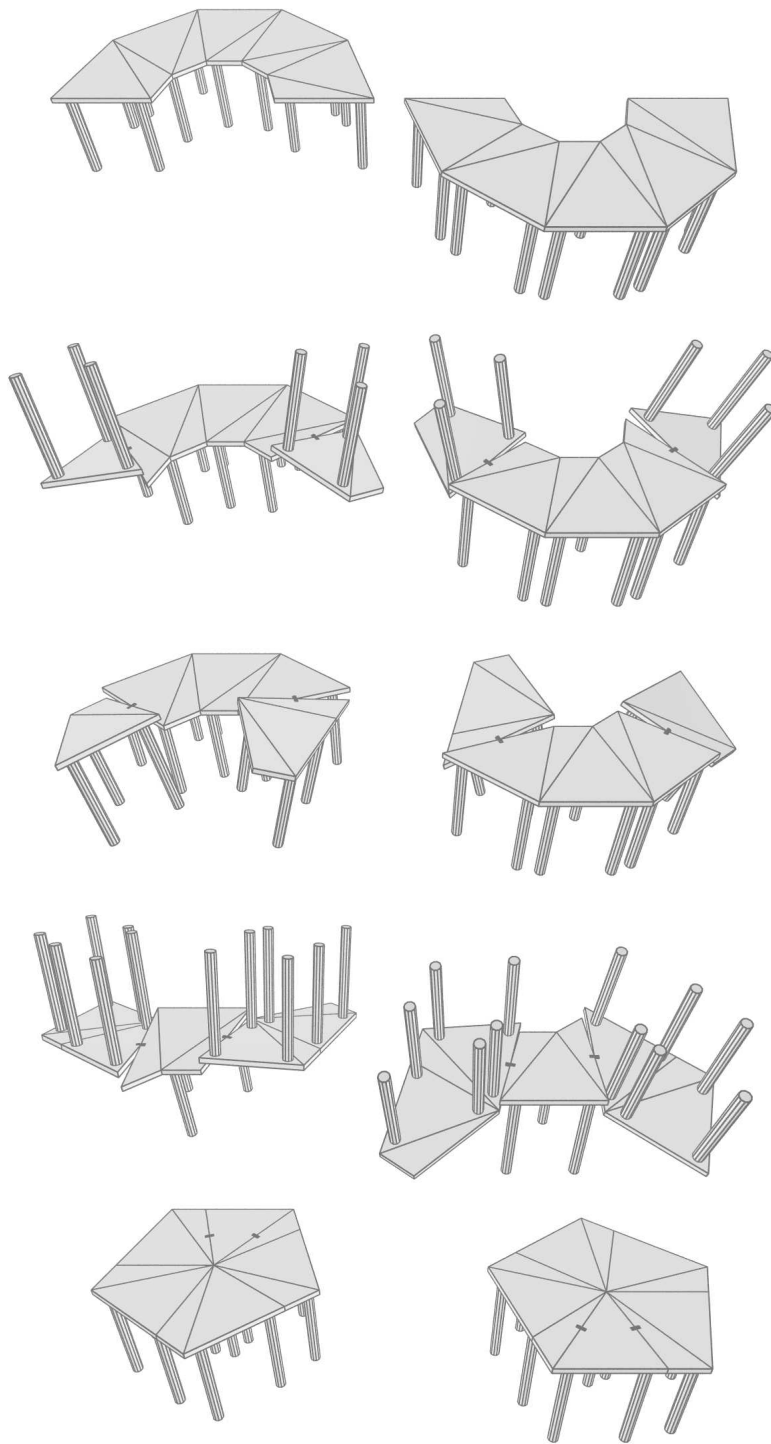

Figure 19: Sequence of perspectives: Decagonal ring to two pentagons

One goal in identifying feasible sequences is to find those that emphasize the symmetry and structure of the dissection. It is possible to perform some number of twists simultaneously, either starting them all at the same instant of time and completing them at the same instant of time, as in Figure 19, or starting one twist, then starting a second twist before the first completes, then a third before the second (or possibly the first) completes, etc. An investigation into what is possible yields yet one more level of art (or design) at work. Animations of a number of the dissections in this paper, realized as reconfigurable benches, are given on the webpage:

http://www.cs.purdue.edu/homes/gnf/book2/bd_anims2.html

Acknowledgements

It is my pleasure to thank an anonymous referee of the conference version [18] for thoughtful comments and suggestions.

References

- [1] Abu'l-Wafā' al-Būzjānī. Kitāb fīmā yahtāju al-sāni' min a' māl al-handasa (On the Geometric Constructions Necessary for the Artisan). Mashhad: Imam Riza 37, copied in the late 10th or the early 11th century. Persian manuscript.
- [2] George Johnston Allman. *Greek Geometry from Thales to Euclid*. Hodges, Figgis & Co., Dublin, 1889.
- [3] Claudi Alsina and Roger B. Nelsen. *Math Made Visual: Creating Images for Understanding Mathematics*. Mathematical Association of America, Washington, DC, 2006.
- [4] Anonymous. Fī tadākhul al-ashkāl al-mutashābiha aw al-mutawāfiqa (Interlocks of Similar or Complementary Figures). Paris: Bibliothèque Nationale, ancien fonds. Persian 169, ff. 180r–199v.

- [5] Anonymous. Künstler, die sich nützlich machen (Artists who make themselves useful). *art: das Kunstmagazin (G.F.R.)*, pages 74–79, December 1987. Art was a monthly periodical published by Verlag Gruner + Jahr in Hamburg, Germany.
- [6] Jean Bauer. Polygons' combinations. Powerpoint slide presentation, 1999.
- [7] Moritz Cantor. *Vorlesungen über Geschichte der Mathematik*, volume 1. B. G. Teubner, Stuttgart, third edition, 1907.
- [8] Henry E. Dudeney. Perplexities. Monthly puzzle column in *The Strand Magazine* from May, 1910 through June, 1930.
- [9] Henry E. Dudeney. Puzzles and prizes. Column in the *Weekly Dispatch*, April 19, 1896–March 27, 1904.
- [10] Henry Ernest Dudeney. *The Canterbury Puzzles and Other Curious Problems*. W. Heinemann, London, 1907.
- [11] William L. Esser, III. Jewelry and the like adapted to define a plurality of objects or shapes. U.S. Patent 4,542,631, 1985.
- [12] Howard Eves. Mathematically motivated designs. Videotaped lecture, 1994. Mathematical Association of America.
- [13] Greg N. Frederickson. *Dissections Plane & Fancy*. Cambridge University Press, New York, 1997.
- [14] Greg N. Frederickson. Geometric dissections that swing and twist. In *Discrete and Computational Geometry, Japanese Conference, JCDCG'00, Lecture Notes in Computer Science, LNCS 2098*, pages 137–148. Springer Verlag, 2000.
- [15] Greg N. Frederickson. Geometric dissections now swing and twist. *Mathematical Intelligencer*, 23(3):9–20, 2001.

- [16] Greg N. Frederickson. *Hinged Dissections: Swinging and Twisting*. Cambridge University Press, New York, 2002.
- [17] Greg N. Frederickson. The heptagon to the square, and other wild twists. November 2005.
- [18] Greg N. Frederickson. Symmetry and structure in twist-hinged dissections of polygonal rings and polygonal anti-rings. In *Proceedings of Bridges Donostia: Mathematics, Music, Art, Architecture, Culture*, pages 21–28, San Sebastian, Spain, 2007.
- [19] Greg N. Frederickson. Unexpected twists in geometric dissections. *Graphs and Combinatorics*, 23[Suppl]:245–258, 2007.
- [20] Johannes Kepler. *Harmonices Mundi Libri V*. Linz, Austria, 1619.
- [21] Harry Lindgren. *Geometric Dissections*. D. Van Nostrand Company, Princeton, New Jersey, 1964.
- [22] Sam Loyd. Weekly puzzle column in *Tit-Bits*, starting in Oct. 3, 1896 and continuing into 1897.
- [23] Sam Loyd. Mental Gymnastics. Puzzle column in Sunday edition of *Philadelphia Inquirer*, October 23, 1898–1901.
- [24] Ernst Lurker. Heart pill. 7 inch tall model in nickel-plated aluminum, limited edition of 80 produced by Bayer, in Germany, 1984.
- [25] Alpay Özdural. Mathematics and arts: Connections between theory and practice in the medieval Islamic world. *Historia Mathematica*, 27:171–201, 2000.
- [26] Erno Rubik. Toy with turnable elements for forming geometric shapes. U.S. Patent 4,392,323, 1983.

- [27] Aydin Sayili. Thâbit ibn Qurra's generalization of the Pythagorean theorem. *Isis*, 51:35-37, 1960.
- [28] Gavin Theobald. Geometric dissections. <http://home.btconnect.com/GavinTheobald/HTML/Index.html>.